

Plain Bore Pulleys 8M Belts

Catalogue No.	No. Teeth Z	Pulley Type	Pitch Circle Diameter dp	Min. Bore d	Max Bore d	Outside Diameter do	Flange Diameter A	Pulley Width F	Bore Length L	Hub Diameter M	Rim Diameter N	Approx. Weight kg
8mm Pitch Pulleys for 20mm wide Belts. Ref. 8M20												
P22-8M-20	22	1F	56.02	12	29	54.7	60	28	38	43	-	0.54
P24-8M-20	24	1F	61.12	12	30	59.8	66	28	38	45	-	0.65
P26-8M-20	26	1F	66.21	12	32	64.9	70	28	38	48	-	0.80
P28-8M-20	28	1F	71.30	15	34	70.1	75	28	38	50	-	0.87
P30-8M-20	30	1F	76.39	15	36	75.1	83	28	38	55	-	1.02
P32-8M-20	32	1F	81.49	15	40	80.2	87	28	38	60	-	1.20
P34-8M-20	34	1F	86.58	15	46	85.2	91	28	38	70	-	1.40
P36-8M-20	36	1F	91.67	15	50	90.3	97	28	38	75	-	1.55
P38-8M-20	38	1F	96.77	15	50	95.4	102	28	38	75	-	1.65
P40-8M-20	40	1F	101.86	15	50	100.5	106	28	38	75	-	1.74
P44-8M-20	44	1F	112.05	15	50	110.7	120	28	38	75	-	2.10
P48-8M-20	48	1F	122.23	15	50	120.9	128	28	38	75	-	2.44
P56-8M-20	56	2F	142.60	15	54	141.2	150	28	38	80	116	2.60
P64-8M-20	64	2F	162.97	15	54	161.6	168	28	38	80	137	2.90
P72-8M-20	72	2F	183.35	15	54	182.0	192	28	38	80	158	3.10
P80-8M-20	80	2	203.72	15	54	202.4	-	28	38	90	180	3.80
P90-8M-20	90	2	229.18	15	54	227.8	-	28	38	90	204	4.20
P112-8M-20	112	2	285.21	18	54	283.8	-	28	38	90	254	5.20
P144-8M-20	144	2	366.69	20	54	365.3	-	28	38	90	336	7.50
P168-8M-20	168	2	427.81	20	60	426.4	-	28	38	100	400	10.00
P192-8M-20	192	2	488.92	20	60	487.6	-	28	38	100	460	14.40
8mm Pitch Pulleys for 30mm wide Belts. Ref. 8M30												
P22-8M-30	22	1F	56.02	12	29	54.7	60	38	48	43	-	0.69
P24-8M-30	24	1F	61.12	12	30	59.8	66	38	48	45	-	0.84
P26-8M-30	26	1F	66.21	12	32	64.9	70	38	48	48	-	1.00
P28-8M-30	28	1F	71.30	15	34	70.1	75	38	48	50	-	1.12
P30-8M-30	30	1F	76.39	15	36	75.1	83	38	48	55	-	1.32
P32-8M-30	32	1F	81.49	15	40	80.2	87	38	48	60	-	1.53
P34-8M-30	34	1F	86.58	15	46	85.2	91	38	48	70	-	1.80
P36-8M-30	36	1F	91.67	15	50	90.3	97	38	48	75	-	1.99
P38-8M-30	38	1F	96.77	15	50	95.4	102	38	48	75	-	2.27
P40-8M-30	40	1F	101.86	15	50	100.5	106	38	48	75	-	2.40
P44-8M-30	44	1F	112.05	15	50	110.7	120	38	48	75	-	2.80
P48-8M-30	48	1F	122.23	15	50	120.9	128	38	48	75	-	3.20
P56-8M-30	56	2F	142.60	15	60	141.2	150	38	48	90	116	3.60
P64-8M-30	64	2F	162.97	15	60	161.6	168	38	48	90	137	4.30
P72-8M-30	72	2F	183.35	15	63	182.0	192	38	48	95	158	4.80
P80-8M-30	80	2	203.72	15	60	202.4	-	38	48	100	180	5.10
P90-8M-30	90	2	229.18	15	60	227.8	-	38	48	100	204	5.70
P112-8M-30	112	2	285.21	18	60	283.8	-	38	48	100	254	6.80
P144-8M-30	144	2	366.69	20	60	365.3	-	38	48	100	336	9.30
P168-8M-30	168	2	427.81	20	60	426.4	-	38	48	100	400	11.40
P192-8M-30	192	2	488.92	20	60	487.6	-	38	48	100	460	16.00
8mm Pitch Pulleys for 50mm wide Belts. Ref. 8M50												
P22-8M-50	22	1F	56.02	12	29	54.7	60	60	70	43	-	1.00
P24-8M-50	24	1F	61.12	12	30	59.8	66	60	70	45	-	1.23
P26-8M-50	26	1F	66.21	15	32	64.9	70	60	70	48	-	1.50
P28-8M-50	28	1F	71.30	15	34	70.1	75	60	70	50	-	1.67
P30-8M-50	30	1F	76.39	15	36	75.1	83	60	70	55	-	1.97
P32-8M-50	32	1F	81.49	15	40	80.2	87	60	70	60	-	2.27
P34-8M-50	34	1F	86.58	15	44	85.2	91	60	70	66	-	2.69
P36-8M-50	36	1F	91.67	15	46	90.3	97	60	70	70	-	2.97
P38-8M-50	38	1F	96.77	15	50	95.4	102	60	70	75	-	3.23
P40-8M-50	40	1F	101.86	18	50	100.5	106	60	70	75	-	3.50
P44-8M-50	44	1F	112.05	18	50	110.7	120	60	70	75	-	3.90
P48-8M-50	48	1F	122.23	18	54	120.9	128	60	70	80	-	4.30
P56-8M-50	56	3F	142.60	18	60	141.2	150	60	60	90	116	5.00
P64-8M-50	64	3F	162.97	18	67	161.6	168	60	60	100	137	5.60
P72-8M-50	72	3F	183.35	18	67	182.0	192	60	60	100	158	6.80
P80-8M-50	80	3	203.72	18	66	202.4	-	60	60	110	180	6.90
P90-8M-50	90	3	229.18	18	66	227.8	-	60	60	110	204	8.60
P112-8M-50	112	3	285.21	18	66	283.8	-	60	60	110	254	9.60
P144-8M-50	144	3	366.69	20	66	365.3	-	60	60	110	336	13.80
P168-8M-50	168	3	427.81	20	72	426.4	-	60	60	120	400	16.00
P192-8M-50	192	3	488.92	20	78	487.6	-	60	60	130	460	22.40
8mm Pitch Pulleys for 85mm wide Belts. Ref. 8M85												
P22-8M-85	22	1F	56.02	12	29	54.7	60	95	105	43	-	1.55
P24-8M-85	24	1F	61.12	12	30	59.8	66	95	105	45	-	1.90
P26-8M-85	26	1F	66.21	12	32	64.9	70	95	105	48	-	2.25
P28-8M-85	28	1F	71.30	15	34	70.1	75	95	105	50	-	2.55
P30-8M-85	30	1F	76.39	15	36	75.1	83	95	105	55	-	3.00
P32-8M-85	32	1F	81.49	15	40	80.2	87	95	105	60	-	3.57
P34-8M-85	34	1F	86.58	15	44	85.2	91	95	105	66	-	4.00
P36-8M-85	36	1F	91.67	15	46	90.3	97	95	105	70	-	4.50
P38-8M-85	38	1F	96.77	15	50	95.4	102	95	105	75	-	5.00
P40-8M-85	40	1F	101.86	18	50	100.5	106	95	105	75	-	5.20
P44-8M-85	44	1F	112.05	18	50	110.7	120	95	105	75	-	6.60
P48-8M-85	48	1F	122.23	18	54	120.9	128	95	105	80	-	7.00
P56-8M-85	56	1F	142.60	18	54	141.2	150	95	105	90	-	10.00
P64-8M-85	64	3F	162.97	20	67	161.6	168	95	95	100	137	10.40
P72-8M-85	72	3F	183.35	20	67	182.0	192	95	95	100	158	11.40
P80-8M-85	80	3	203.72	20	66	202.4	-	95	95	110	180	11.10
P90-8M-85	90	3	229.18	20	66	227.8	-	95	95	110	204	12.20
P112-8M-85	112	3	285.21	24	66	283.8	-	95	95	110	254	15.00
P144-8M-85	144	3	366.69	24	66	365.3	-	95	95	110	336	21.50
P168-8M-85	168	3	427.81	24	72	426.4	-	95	95	120	400	24.10
P192-8M-85	192	3	488.92	24	78	487.6	-	95	95	130	460	30.60

Pulley Types

The Pulley types referred to in tables are as drawings below. Suffix 'F' indicates pulley has flanges. Pulley below dividing line in tables are manufactured in cast iron. Pulleys 112 teeth (80 teeth on 8M-85) and above incorporate lightening holes in design.

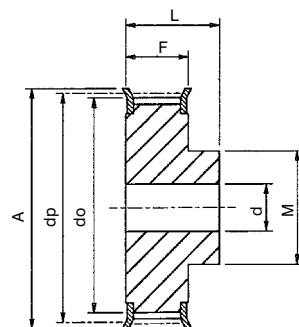

Type 1F
Material: Steel

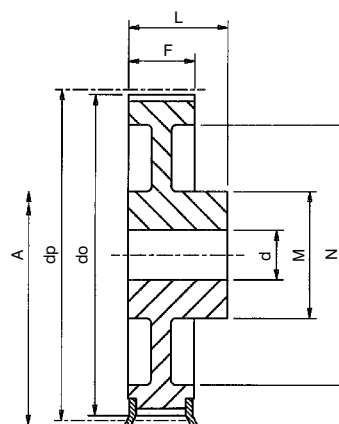

Type 2/2F
Material: Steel or Cast Iron

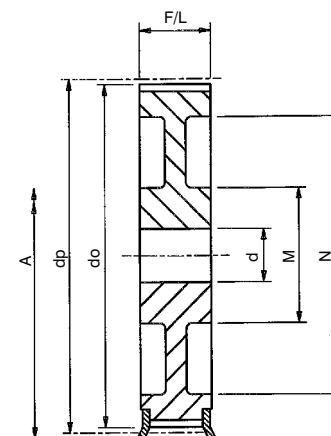

Type 3/3F
Material: Steel or Cast Iron

*Non-stock items, manufactured to customer order only. All dimensions in mm. Standard Pulleys can be reworked to customers bore and keyway requirements