

General Information

Material and Groove Specifications:

Challenge V pulleys are manufactured from fine grain grey cast iron grade GG25 and are phosphated.

Groove dimensions conform to ISO 4183 for both eccentricity of outside diameter to bore and groove side wobble tolerance.

They are suitable for use with all wedge belts according to ISO 4184 and all classical V-belts according to ISO 4184.

Peripheral Speeds:

Peripheral (rim) speeds of up to 40 m/s are permissible

Balancing Specifications:

All Challenge pulleys are balanced to grade Q6.3 or better.

- Pulleys with a weight of 100kg and above are dynamically balanced (two planes).
- All pulleys with a weight less than 100kg are statically machine balanced (one plane).

V-belt Pulleys to ISO 4183

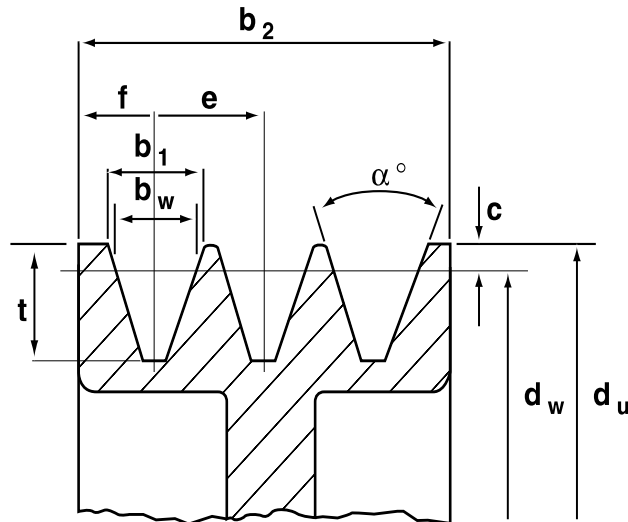

Profile	dw (mm)	α°	b1	bw	c	f	e	tmin
SPZ	Up to 80	34	9.7	8.5	2.0	8±0.3	12±0.3	11+0.6
	Over 80	38						
SPA	Up to 118	34	12.7	11.0	2.8	10±0.3	15±0.3	14+0.6
	Over 118	38						
SPB	Up to 190	34	16.3	14.0	3.5	12.5±0.4	19±0.4	18+0.6
	Over 190	38						
SPC	Up to 315	34	22.0	19.0	4.8	17±0.5	25.5±0.5	24+0.6
	Over 315	38						

Face Width of Pulleys, b_2

No. of Grooves	1	2	3	4	5	6	8	10	12
SPZ	16	28	40	52	64	76	100	-	-
SPA	20	35	50	65	80	95	-	-	-
SPB	25	44	63	82	101	120	158	196	-
SPC	-	-	85	110.5	136	161.5	212.5	263.5	314.5

Pitch Dia. dw	Outside Dia. du	Groove No.	Bush Size	Max Bore	Pulley Config. & Style	Rim Width B	L	N	Weight kg
56	60	1	1008	25	S1	15	35	22	0.5
56	60	2	1108	28	S1	27	47	22	0.5
60	64	1	1008	25	S1	15	23	22	0.3
60	64	2	1108	28	S1	27	47	22	0.7
63	67	1	1108	28	S3	16	23	7	0.3
63	67	2	1108	28	S6	28	23	5	0.3
63	67	3	1108	28	S6	40	23	17	0.5
67	71	1	1108	28	S3	16	23	7	0.3
67	71	2	1108	28	S6	28	23	5	0.4
67	71	3	1108	28	S6	40	23	17	0.6
71	75	1	1108	28	S3	16	23	7	0.4
71	75	2	1108	28	S6	28	23	5	0.5
71	75	3	1108	28	S6	40	23	17	0.6
71	75	4	1108	28	S6	52	23	29	0.8
75	79	1	1108	28	S3	16	23	7	0.4
75	79	2	1210	32	S6	28	26	2	0.6
75	79	3	1210	32	S6	40	26	14	0.6
75	79	4	1210	32	S6	52	26	27	0.9
80	84	1	1210	32	S3	16	26	10	0.5
80	84	2	1210	32	S6	28	26	2	0.6
80	84	3	1210	32	S6	40	26	14	0.8
80	84	4	1210	32	S6	52	26	26	0.9
85	89	1	1210	32	S3	16	26	10	0.6
85	89	2	1610	42	S6	28	26	2	0.7
85	89	3	1610	42	S6	40	26	14	0.8
85	89	4	1610	42	S6	52	26	26	0.9
85	89	5	1610	42	S6	64	26	38	1.3
90	94	1	1210	32	S3	16	26	10	0.7
90	94	2	1610	42	S6	28	26	2	0.7
90	94	3	1610	42	S6	40	26	14	0.9
90	94	4	1610	42	S6	52	26	26	1.1
90	94	5	1610	42	S6	64	26	38	1.4
90	94	6	1610	42	S6	76	26	50	1.6
95	99	1	1210	32	S3	16	26	10	0.8
95	99	2	1610	42	S6	28	26	2	0.8
95	99	3	1610	42	S6	40	26	14	1.1
95	99	4	1610	42	S6	52	26	26	1.3
95	99	5	1610	42	S6	64	26	38	1.6
95	99	6	1610	42	S6	76	26	50	1.8
100	104	1	1210	32	S3	16	26	10	0.8
100	104	2	1610	42	S6	28	26	2	1.0
100	104	3	1610	42	S6	40	26	14	1.2
100	104	4	1610	42	S6	52	26	26	1.4
100	104	5	2012	50	S6	64	32	32	1.6
100	104	6	2012	50	S6	76	32	44	1.9
106	110	1	1610	42	S3	16	26	10	0.9
106	110	2	1610	42	S6	28	26	2	1.2
106	110	3	1610	42	S6	40	26	14	1.4
106	110	4	1610	42	S6	52	26	26	1.6
106	110	5	2012	50	S6	64	32	32	1.9
106	110	6	2012	50	S6	76	32	44	2.2
112	116	1	1610	42	S3	16	26	10	1.0
112	116	2	1610	42	S6	28	26	2	1.4
112	116	3	2012	50	S6	40	32	8	1.5
112	116	4	2012	50	S6	52	32	20	1.7
112	116	5	2012	50	S6	64	32	32	2.2
112	116	6	2012	50	S6	76	32	44	2.5
118	122	1	1610	42	S3	16	26	10	1.1
118	122	2	1610	42	S6	28	26	2	1.6
118	122	3	2012	50	S6	40	32	8	1.7
118	122	4	2012	50	S4	52	32	20	2.0
118	122	5	2012	50	S6	64	32	32	2.3
118	122	6	2517	65	S6	76	45	31	2.5

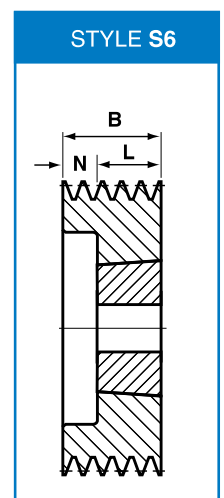
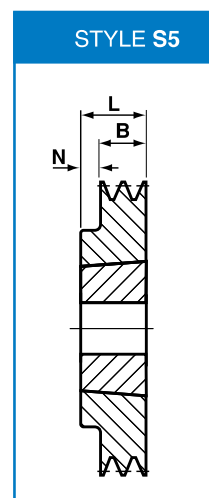
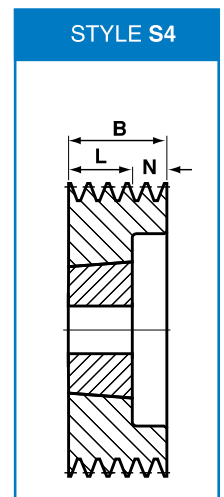
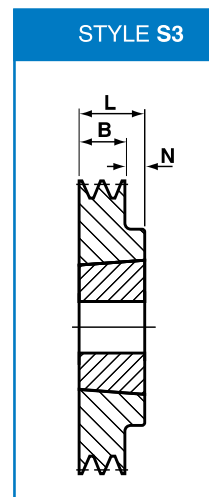
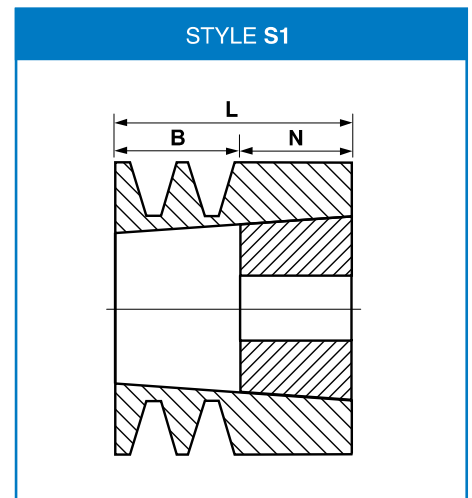

Pulley Configuration: S=Solid, P=Plate, A=Arm.
= lightening holes

SPZ

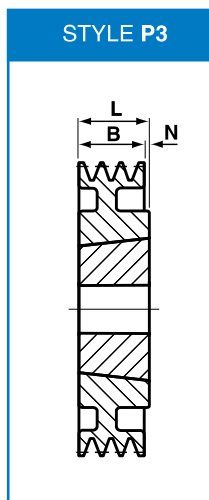
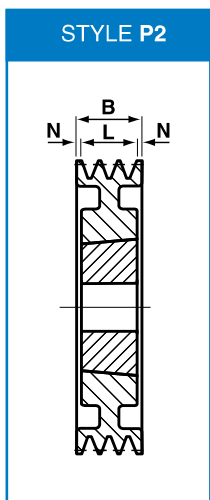
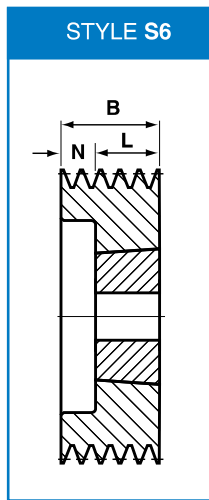
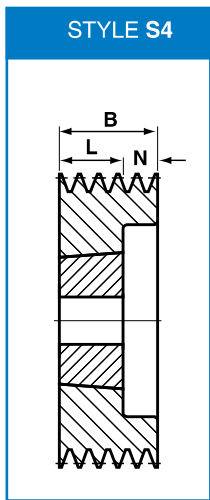
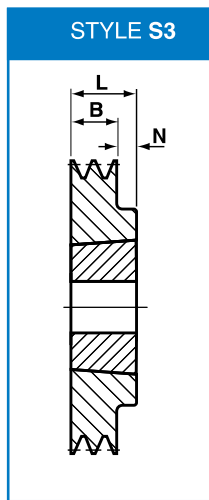
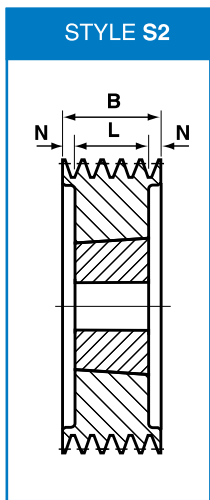

Pitch Dia. dw	Outside Dia. du	Groove No.	Bush Size	Max Bore	Pulley Config. & Style	Rim Width B	L	N	Weight kg
125	129	1	1610	42	S3	16	26	10	1.2
125	129	2	1610	42	S6	28	26	2	1.8
125	129	3	2012	50	S6	40	32	8	2.1
125	129	4	2012	50	S4	52	32	20	2.3
125	129	5	2012	50	S6	64	32	32	2.7
125	129	6	2517	65	S6	76	45	31	3.0
132	136	1	1610	42	S3	16	26	10	1.4
132	136	2	1610	42	S6	28	26	2	2.1
132	136	3	2012	50	S6	40	32	8	2.4
132	136	4	2012	50	S6	52	32	20	2.7
132	136	5	2517	65	S6	64	45	19	3.2
132	136	6	2517	65	S6	76	45	31	3.5
140	144	1	1610	42	P3	16	26	10	1.6
140	144	2	1610	42	S6	28	26	2	2.4
140	144	3	2012	50	S4	40	32	8	2.8
140	144	4	2012	50	S4	52	32	20	3.2
140	144	5	2517	65	S4	64	45	19	3.5
140	144	6	2517	65	S4	76	45	31	3.9
150	154	1	1610	42	P3	16	26	10	1.9
150	154	2	2012	50	S3	28	32	4	2.6
150	154	3	2012	50	S4	40	32	8	3.4
150	154	4	2517	65	S4	52	45	7	3.9
150	154	5	2517	65	S4	64	45	19	4.3
150	154	6	2517	65	S4	76	45	31	4.7
160	164	1	1610	42	P3	16	26	10	2.1
160	164	2	2012	50	S3	28	32	4	3.1
160	164	3	2012	50	S4	40	32	8	3.9
160	164	4	2517	65	S4	52	45	7	4.7
160	164	5	2517	65	S4	64	45	19	5.1
160	164	6	2517	65	S4	76	45	31	5.5
170	174	1	1610	42	P3	16	26	10	1.7
170	174	2	2012	50	P3	28	32	4	3.4
170	174	3	2012	50	P4	40	32	8	4.3
170	174	4	2517	65	S4	52	45	7	5.4
170	174	5	2517	65	S4	64	45	19	6.1
170	174	6	2517	65	S4	76	45	31	6.7
180	184	1	1610	42	P3	16	26	10	1.8
180	184	2	2012	50	P3	28	32	4	2.7
180	184	3	2012	50	P4	40	32	8	3.3
180	184	4	2517	65	S4	52	45	7	6.5
180	184	5	2517	65	S4	64	45	19	6.9
180	184	6	2517	65	S4	76	45	31	7.3
190	194	1	1610	42	P3	16	26	10	2.5
190	194	2	2012	50	P3	28	32	4	3.2
190	194	3	2012	50	P4	40	32	8	5.1
190	194	4	2517	65	P4	52	45	7	5.5
190	194	5	2517	65	S2	64	45	9.5	6.5
190	194	6	2517	65	S2	76	45	15.5	7.2
190	194	8	2517	65	S2	100	45	27.5	8.5
200	204	1	2012	50	P3	16	32	16	3.2
200	204	2	2012	50	P3	28	32	4	3.4
200	204	3	2012	50	P4	40	32	8	3.6
200	204	4	2517	65	P4	52	45	7	5.4
200	204	5	2517	65	P2	64	45	9.5	6.1
200	204	6	2517	65	P2	76	45	15.5	6.6
200	204	8	2517	65	P2	100	45	27.5	9.6
224	228	1	2012	50	A3	16	32	16	2.8
224	228	2	2012	50	P3	28	32	4	3.5
224	228	3	2012	50	P4	40	32	8	4.2
224	228	4	2517	65	P4	52	45	7	6.3
224	228	5	2517	65	P2	64	45	9.5	7.0
224	228	6	2517	65	P2	76	45	15.5	7.6
224	228	8	2517	65	P2	100	45	27.5	12.3

Pulley Configuration: S=Solid, P=Plate, A=Arm.
= lightening holes

All dimensions in millimetres unless otherwise stated. Every effort has been taken to ensure that the data listed in this catalogue is correct. Challenge accepts no liability for any inaccuracies or damage caused

Pitch Dia. dw	Outside Dia. du	Groove No.	Bush Size	Max Bore	Pulley Config. & Style	Rim Width B	L	N	Weight kg
250	254	1	2012	50	A3	16	32	16.0	3.2
250	254	2	2012	50	A3	28	32	4.0	3.9
250	254	3	2012	50	A4	40	32	8.0	4.7
250	254	4	2517	65	P4#	52	45	7.0	6.8
250	254	5	2517	65	P2#	64	45	9.5	8.1
250	254	6	2517	65	P2#	76	45	15.5	8.3
250	254	8	2517	65	P2#	100	45	27.5	10.2
280	284	1	2012	50	A1	16	32	8.0	4.6
280	284	2	2012	50	A3	28	32	4.0	5.4
280	284	3	2517	65	A3	40	45	5.0	7.3
280	284	4	2517	65	A4	52	45	7.0	8.1
280	284	5	2517	65	A2	64	45	9.5	9.8
280	284	6	2517	65	A2	76	45	15.5	9.9
280	284	8	2517	65	A2	100	45	27.5	11.2
315	319	1	2012	50	A1	16	32	8.0	5.8
315	319	2	2012	50	A3	28	32	4.0	6.4
315	319	3	2517	65	A3	40	45	5.0	8.3
315	319	4	2517	65	A4	52	45	7.0	9.2
315	319	5	2517	65	A2	64	45	9.5	11.0
315	319	6	2517	65	A2	76	45	15.5	11.5
315	319	8	2517	65	A2	100	45	27.5	13.9
355	359	1	2012	50	A1	16	32	8.0	4.0
355	359	2	2012	50	A3	28	32	4.0	6.5
355	359	3	2517	65	A3	40	45	5.0	8.9
355	359	4	2517	65	A4	52	45	7.0	9.5
355	359	5	2517	65	A2	64	45	9.5	14.8
355	359	6	2517	65	A2	76	45	15.5	14.8
355	359	8	3030	75	A2	100	45	27.5	17.0
400	404	1	2012	50	A1	16	32	8.0	6.0
400	404	2	2517	65	A3	28	45	17.0	8.8
400	404	3	2517	65	A3	40	45	5.0	10.5
400	404	4	2517	65	A4	52	45	7.0	11.5
400	404	5	3020	75	A2	64	52	6.0	13.8
* 400	404	6	3030	75	A3	76	77	1.0	17.6
* 400	404	8	3030	75	A2	100	77	12.0	19.0
450	454	2	2517	65	A1	28	45	8.5	11.1
450	454	3	2517	65	A3	40	45	5.0	11.6
450	454	4	3020	75	A2	52	52	-	11.7
450	454	5	3020	75	A2	64	52	6.0	18.0
450	454	6	3030	75	A3	76	77	1.0	21.6
450	454	8	3030	75	A2	100	77	12.0	22.6
500	504	2	2517	65	A1	28	45	8.5	12.2
500	504	3	2517	65	A3	40	45	5.0	10.1
500	504	4	3020	75	A2	52	52	-	12.4
500	504	5	3030	75	A1	64	77	6.5	22.3
500	504	6	3030	75	A3	76	77	1.0	24.5
500	504	8	3030	75	A2	100	77	11.5	28.0
630	634	3	2517	65	A3	40	45	5.0	17.4
630	634	4	3030	75	A1	52	77	12.5	24.0
630	634	5	3030	75	A1	64	77	6.5	27.6
630	634	6	3535	90	A1	76	89	6.5	33.0
630	634	8	3535	90	A2	100	89	5.5	40.0
* 800	804	4	3030	75	A1	52	77	12.5	28.4
* 800	804	5	3535	90	A2	64	89	12.5	33.1
* 800	804	6	3535	90	A2	76	89	6.5	40.6
* 800	804	8	3535	90	A2	100	89	5.5	43.6

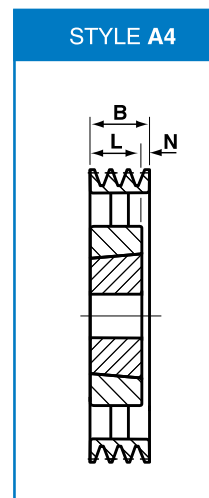
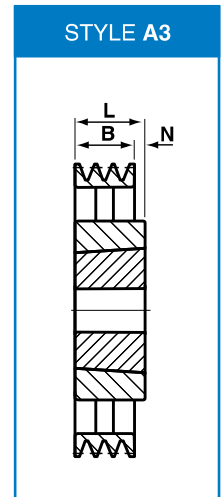
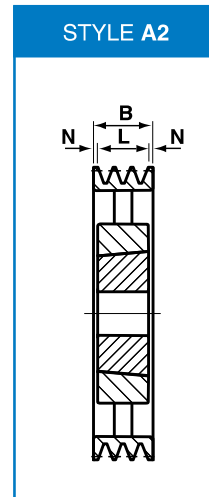
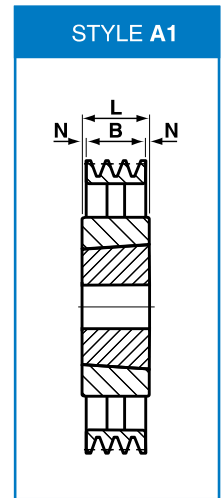
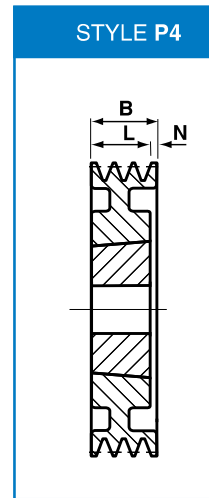

Pulley Configuration: S=Solid, P=Plate, A=Arm.

= lightening holes

* = Not stocked, available to order

SPA

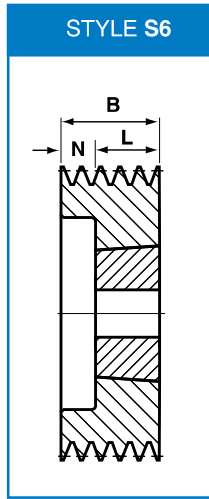
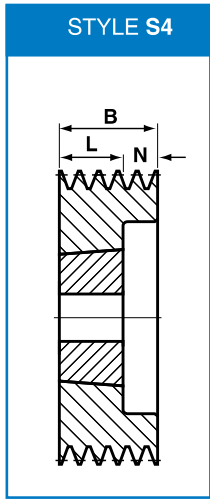
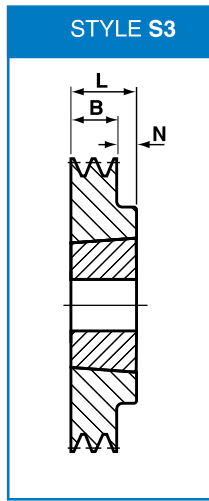
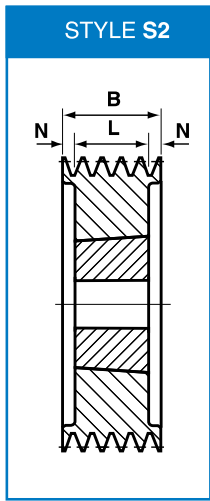

Pitch Dia. dw	Outside Dia. du	Groove No.	Bush Size	Max Bore	Pulley Config. & Style	Rim Width B	L	N	Weight kg
63	68.5	1	1108	28	S3	20	23	21.0	0.6
63	68.5	2	1108	28	S6	35	23	12.0	0.8
67	72.5	1	1108	28	S3	20	23	3.0	0.4
67	72.5	2	1108	28	S6	35	23	12.0	0.6
71	76.5	1	1108	28	S3	20	23	3.0	0.4
71	76.5	2	1108	28	S6	35	23	12.0	0.6
71	76.5	3	1108	28	S6	50	23	27.0	0.8
75	80.5	1	1108	28	S3	20	23	3.0	0.5
75	80.5	2	1108	28	S6	35	23	12.0	0.6
75	80.5	3	1108	28	S6	50	23	27.0	0.8
80	85.5	1	1210	32	S3	20	26	6.0	0.6
80	85.5	2	1210	32	S6	35	26	9.0	0.6
80	85.5	3	1210	32	S6	50	26	24.0	0.9
85	90.5	1	1210	32	S3	20	26	6.0	0.6
85	90.5	2	1210	32	S6	35	26	9.0	0.7
85	90.5	3	1210	32	S6	50	26	24.0	1.1
90	95.5	1	1210	32	S3	20	26	6.0	0.8
90	95.5	2	1610	42	S6	35	26	9.0	0.8
90	95.5	3	1610	42	S6	50	26	24.0	1.1
90	95.5	4	1615	42	S6	65	38	27.0	1.4
90	95.5	5	1615	42	S6	80	38	42.0	1.6
95	100.5	1	1210	32	S3	20	26	6.0	0.9
95	100.5	2	1610	42	S6	35	26	9.0	0.9
95	100.5	3	1610	42	S6	50	26	24.0	1.3
95	100.5	4	1615	42	S6	65	38	27.0	1.7
95	100.5	5	1615	42	S6	80	38	42.0	1.9
100	105.5	1	1610	42	S3	20	26	6.0	0.9
100	105.5	2	1610	42	S6	35	26	9.0	1.1
100	105.5	3	1610	42	S6	50	26	24.0	1.4
100	105.5	4	1615	42	S6	65	38	27.0	1.9
100	105.5	5	1615	42	S6	80	38	42.0	2.0
100	105.5	6	1615	42	S6	95	38	57.0	2.4
106	111.5	1	1610	42	S3	20	26	6.0	0.9
106	111.5	2	1610	42	S6	35	26	9.0	1.2
106	111.5	3	1610	42	S6	50	26	24.0	1.6
106	111.5	4	2012	50	S6	65	32	33.0	1.9
106	111.5	5	2012	50	S6	80	32	48.0	2.3
106	111.5	6	2012	50	S6	95	32	63.0	2.6
112	117.5	1	1610	42	S3	20	26	6.0	1.0
112	117.5	2	1610	42	S6	35	26	9.0	1.4
112	117.5	3	2012	50	S6	50	32	18.0	1.8
112	117.5	4	2012	50	S6	65	32	33.0	2.2
112	117.5	5	2012	50	S6	80	32	48.0	2.6
112	117.5	6	2012	50	S6	95	32	63.0	2.7
118	123.5	1	1610	42	S3	20	26	6.0	1.2
118	123.5	2	1610	42	S6	35	26	9.0	1.6
118	123.5	3	2012	50	S6	50	32	18.0	2.1
118	123.5	4	2012	50	S6	65	32	33.0	2.5
118	123.5	5	2012	50	S4	80	32	48.0	2.8
118	123.5	6	2012	50	S4	95	32	63.0	2.9
125	130.5	1	1610	42	S3	20	26	6.0	1.4
125	130.5	2	1610	42	S4	35	26	10.0	1.9
125	130.5	3	2012	50	S4	50	32	18.0	2.3
125	130.5	4	2012	50	S4	65	32	33.0	2.8
125	130.5	5	2012	50	S2	80	32	24.0	3.3
125	130.5	6	2012	50	S2	95	32	31.5	3.8
132	137.5	1	1610	42	S3	20	26	6.0	1.6
132	137.5	2	2012	50	S4	35	32	3.0	2.2
132	137.5	3	2012	50	S4	50	32	18.0	2.7
132	137.5	4	2517	65	S4	65	45	20.0	3.2
132	137.5	5	2517	65	S2	80	45	17.5	3.8
132	137.5	6	2517	65	S2	95	45	25.0	3.8

Pulley Configuration: S=Solid, P=Plate, A=Arm.
= lightening holes

Pitch Dia. dw	Outside Dia. du	Groove No.	Bush Size	Max Bore	Pulley Config. & Style	Rim Width B	L	N	Weight kg
140	145.5	1	1610	42	S3	20	26	6.0	1.8
140	145.5	2	2012	50	S6	35	32	3.0	2.6
140	145.5	3	2517	65	S4	50	45	5.0	3.0
140	145.5	4	2517	65	S4	65	45	20.0	3.6
140	145.5	5	2517	65	S2	80	45	17.5	4.1
140	145.5	6	2517	65	S2	95	45	25.0	4.1
150	155.5	1	1610	42	S3	20	26	6.0	2.2
150	155.5	2	2012	50	S6	35	32	3.0	3.1
150	155.5	3	2517	65	S4	50	45	5.0	3.7
150	155.5	4	2517	65	S4	65	45	20.0	4.3
150	155.5	5	2517	65	S2	80	45	17.5	4.9
150	155.5	6	2517	65	S2	95	45	25.0	5.7
160	165.5	1	1610	42	P3	20	26	6.0	2.5
160	165.5	2	2012	50	S6	35	32	3.0	3.8
160	165.5	3	2517	65	S4	50	45	5.0	4.5
160	165.5	4	2517	65	S4	65	45	20.0	5.1
160	165.5	5	2517	65	S2	80	45	17.5	5.8
160	165.5	6	2517	65	S2	95	45	25.0	6.4
170	175.5	1	1610	42	P3	20	26	6.0	2.0
170	175.5	2	2012	50	S6	35	32	3.0	3.3
170	175.5	3	2517	65	S4	50	45	5.0	4.5
170	175.5	4	2517	65	S4	65	45	20.0	5.9
170	175.5	5	2517	65	S2	80	45	17.5	6.6
170	175.5	6	2517	65	S2	95	45	25.0	7.3
180	185.5	1	1610	42	P3	20	26	6.0	2.4
180	185.5	2	2012	50	P6	35	32	3.0	4.8
180	185.5	3	2517	65	S4	50	45	5.0	6.2
180	185.5	4	2517	65	S4	65	45	20.0	6.9
180	185.5	5	3020	75	S4	80	52	28.0	7.0
180	185.5	6	3020	75	S2	95	52	21.5	8.5
190	195.5	1	2012	50	P3	20	32	12.0	2.7
190	195.5	2	2012	50	P4	35	32	3.0	4.4
190	195.5	3	2517	65	P4	50	45	5.0	5.5
190	195.5	4	3020	75	S4	65	52	13.0	7.2
190	195.5	5	3020	75	S4	80	52	28.0	7.7
190	195.5	6	3020	75	S2	95	52	21.5	10.0
200	205.5	1	2012	50	P3	20	32	12.0	3.2
200	205.5	2	2517	65	P3	35	45	10.0	5.0
200	205.5	3	2517	65	P4	50	45	5.0	5.8
200	205.5	4	3020	75	S4	65	52	13.0	8.4
200	205.5	5	3020	75	S4	80	52	28.0	9.3
200	205.5	6	3020	75	S2	95	52	21.5	12.0
212	217.5	1	2012	50	P3	20	32	12.0	2.9
212	217.5	2	2517	65	P3	35	45	10.0	4.7
212	217.5	3	2517	65	P4	50	45	5.0	6.0
212	217.5	4	3020	75	S4	65	52	13.0	7.8
212	217.5	5	3020	75	S2	80	52	14.0	9.5
212	217.5	6	3020	75	S2	95	52	21.5	14.0
224	229.5	1	2012	50	A3	20	32	12.0	3.7
224	229.5	2	2517	65	P3	35	45	10.0	5.7
224	229.5	3	2517	65	P4	50	45	5.0	6.7
224	229.5	4	3020	75	P4	65	52	13.0	11.0
224	229.5	5	3020	75	S4	80	52	28.0	12.0
224	229.5	6	3020	75	S2	95	52	21.5	14.8
236	241.5	1	2012	50	P3#	20	32	12.0	3.2
236	241.5	2	2517	65	P3#	35	45	10.0	5.4
236	241.5	3	2517	65	P4	50	45	5.0	6.6
236	241.5	4	3020	75	P4	65	52	13.0	9.8
236	241.5	5	3020	75	P4	80	52	28.0	12.2
236	241.5	6	3020	75	S2	95	52	21.5	12.5

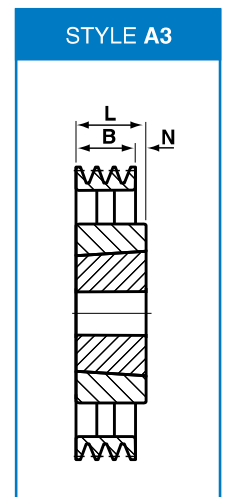
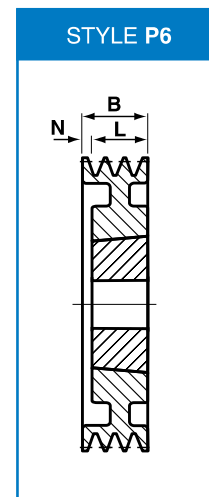
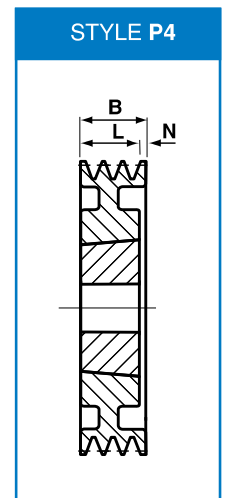
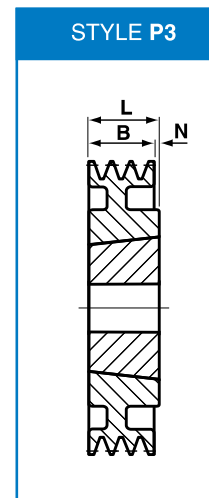

Pulley Configuration: S=Solid, P=Plate, A=Arm.
= lightening holes

SPA

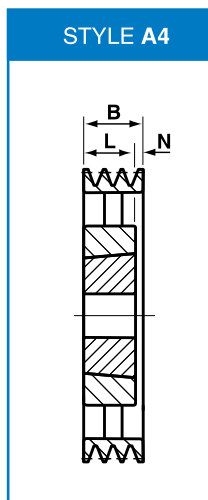
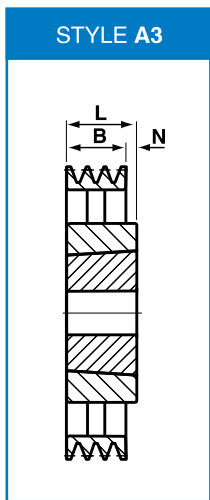
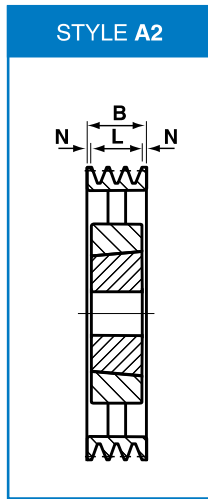
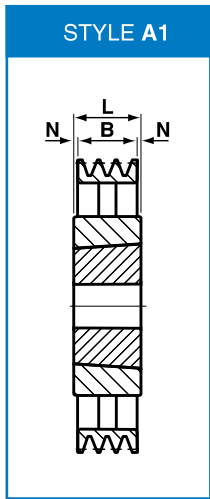
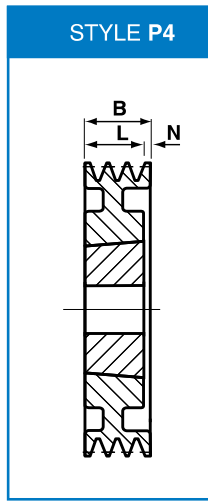
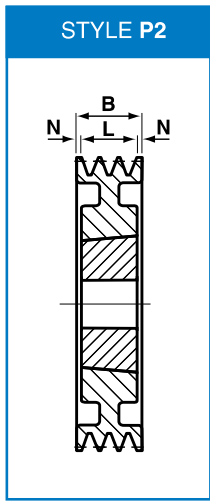

Pitch Dia. dw	Outside Dia. du	Groove No.	Bush Size	Max Bore	Pulley Config. & Style	Rim Width B	L	N	Weight kg
250	255.5	1	2012	50	A3	20	32	12.0	4.4
250	255.5	2	2517	65	A3	35	45	10.0	6.4
250	255.5	3	2517	65	P4#	50	45	5.0	7.5
250	255.5	4	3020	75	P4	65	52	13.0	9.8
250	255.5	5	3020	75	P4	80	52	28.0	11.0
250	255.5	6	3020	75	S2	95	52	21.5	17.5
280	285.5	1	2012	50	A3	20	32	12.0	5.2
280	285.5	2	2517	65	A3	35	45	10.0	7.3
280	285.5	3	2517	65	A4	50	45	5.0	8.4
280	285.5	4	3020	75	P2#	65	52	6.5	11.0
280	285.5	5	3535	90	P3	80	89	9.0	17.0
280	285.5	6	3535	90	P4	95	89	6.0	19.1
300	305.5	1	2012	50	A3	20	32	12.0	4.3
300	305.5	2	2517	65	A3	35	45	10.0	6.2
300	305.5	3	3020	75	A4	50	52	2.0	9.3
300	305.5	4	3020	75	P2#	65	52	6.5	12.4
300	305.5	5	3535	90	P3#	80	89	9.0	16.5
300	305.5	6	3535	90	P4	95	89	6.0	19.5
315	320.5	1	2012	50	A3	20	32	12.0	6.3
315	320.5	2	2517	65	A3	35	45	10.0	9.2
315	320.5	3	3020	75	A3	50	52	2.0	11.0
315	320.5	4	3020	75	A2	65	52	6.5	13.0
315	320.5	5	3535	90	P3#	80	89	9.0	19.0
315	320.5	6	3535	90	P4#	95	89	6.0	24.0
355	360.5	1	2012	50	A3	20	32	12.0	5.6
355	360.5	2	2517	65	A3	35	45	10.0	9.0
355	360.5	3	3020	75	A3	50	52	2.0	12.0
355	360.5	4	3020	75	A2	65	52	6.5	13.0
355	360.5	5	3535	90	A3	80	89	9.0	20.0
355	360.5	6	3535	90	A4	95	89	6.0	24.2
400	405.5	1	2012	50	A3	20	32	12.0	6.4
400	405.5	2	2517	65	A3	35	45	10.0	10.0
400	405.5	3	3020	75	A3	50	52	2.0	13.0
400	405.5	4	3020	75	A2	65	52	6.5	14.5
400	405.5	5	3535	90	A3	80	89	9.0	21.5
400	405.5	6	3535	90	A4	95	89	6.0	25.1
450	455.5	1	2012	50	A3	20	32	12.0	6.2
450	455.5	2	2517	65	A3	35	45	10.0	11.5
450	455.5	3	3020	75	A3	50	52	2.0	14.5
450	455.5	4	3020	75	A2	65	52	6.5	16.5
450	455.5	5	3535	90	A3	80	89	9.0	23.0
450	455.5	6	3535	90	A4	95	89	6.0	40.0
500	505.5	1	2517	65	A3	20	45	25.0	6.5
500	505.5	2	2517	65	A3	35	45	10.0	12.5
500	505.5	3	3020	75	A3	50	52	2.0	15.5
500	505.5	4	3020	75	A2	65	52	6.5	18.0
500	505.5	5	3535	90	A3	80	89	9.0	25.0
500	505.5	6	3535	90	A4	95	89	6.0	54.2
560	565.5	2	3020	75	A3	35	52	17.0	18.4
560	565.5	3	3020	75	A3	50	52	2.0	16.0
560	565.5	4	3535	90	A1	65	89	12.0	23.5
560	565.5	5	3535	90	A3	80	89	9.0	27.0
560	565.5	6	3535	90	A4	95	89	6.0	55.1
630	635.5	2	3020	75	A3	35	52	17.0	20.5
630	635.5	3	3020	75	A3	50	52	2.0	20.0
630	635.5	4	3535	90	A3	65	89	24.0	28.0
630	635.5	5	3535	90	A3	80	89	9.0	31.0
630	635.5	6	4040	100	A3	95	102	7.0	56.3
800	805.5	3	3535	90	A3	50	89	39.0	36.0
800	805.5	4	3535	90	A3	65	89	24.0	46.0
800	805.5	5	4040	100	A1	80	102	11.0	55.5
800	805.5	6	4040	100	A3	95	102	7.0	66.0

Pulley Configuration: S=Solid, P=Plate, A=Arm.
= lightening holes

Pitch Dia. dw	Outside Dia. du	Groove No.	Bush Size	Max Bore	Pulley Config. & Style	Rim Width B	L	N	Weight kg
100	107	1	1610	42	S3	25	26	1.0	0.9
100	107	2	1610	42	S6	44	26	18.0	1.4
100	107	3	1610	42	S6	63	26	37.0	1.9
106	113	1	1610	42	S3	25	26	1.0	1.0
106	113	2	1610	42	S6	44	26	18.0	1.5
106	113	3	1610	42	S6	63	26	37.0	2.0
112	119	1	1610	42	S3	25	26	1.0	1.2
112	119	2	1610	42	S4	44	26	18.0	1.7
112	119	3	1610	42	S6	63	26	37.0	2.3
118	125	1	1610	42	S3	25	26	1.0	1.3
118	125	2	1610	42	S4	44	26	18.0	1.9
118	125	3	1610	42	S6	63	26	37.0	2.6
125	132	1	1610	42	S3	25	26	1.0	1.5
125	132	2	2012	50	S4	44	32	12.0	2.3
125	132	3	2012	50	S4	63	32	31.0	2.3
125	132	4	2012	50	S2	82	32	25.0	3.7
125	132	5	2012	50	S6	101	32	69.0	4.4
132	139	1	1610	42	S3	25	26	1.0	1.8
132	139	2	2012	50	S4	44	32	12.0	2.4
132	139	3	2012	50	S4	63	32	31.0	3.1
132	139	4	2012	50	S2	82	32	25.0	3.8
132	139	5	2517	60	S6	101	45	56.0	4.6
140	147	1	1610	42	S3	25	26	1.0	2.1
140	147	2	2012	50	S4	44	32	12.0	2.8
140	147	3	2012	50	S4	63	32	31.0	3.6
140	147	4	2517	65	S2	82	45	18.5	4.5
140	147	5	2517	65	S2	101	45	28.0	5.3
140	147	6	2517	65	S2	120	45	37.5	6.1
150	157	1	1610	42	S3	25	26	1.0	2.5
150	157	2	2012	50	S4	44	32	12.0	3.4
150	157	3	2517	65	S4	63	45	18.0	4.1
150	157	4	2517	65	S2	82	45	18.5	4.9
150	157	5	2517	65	S2	101	45	28.0	5.8
150	157	6	2517	65	S2	120	45	37.5	6.6
160	167	1	1610	42	S3	25	26	1.0	2.9
160	167	2	2012	50	S6	44	32	12.0	3.9
160	167	3	2517	65	S6	63	45	18.0	4.9
160	167	4	2517	65	S2	82	45	18.5	5.8
160	167	5	2517	65	S2	101	45	28.0	6.7
160	167	6	3020	75	S2	120	52	34.0	6.5
160	167	8	3020	75	S2	158	52	53.0	8.5
170	177	1	1610	42	P3	25	26	1.0	3.3
170	177	2	2012	50	S6	44	32	12.0	4.5
170	177	3	2517	65	S6	63	45	18.0	5.8
170	177	4	2517	65	S2	82	45	18.5	6.7
170	177	5	3020	75	S2	101	52	24.5	6.8
170	177	6	3020	75	S2	120	52	34.0	7.8
170	177	8	3030	75	S2	158	77	40.5	11.0
180	187	1	1610	42	P3	25	26	1.0	3.8
180	187	2	2517	65	S3	44	45	1.0	5.3
180	187	3	2517	65	S6	63	45	18.0	6.7
180	187	4	2517	65	S2	82	45	18.5	7.7
180	187	5	3020	75	S2	101	52	24.5	8.0
180	187	6	3020	75	S2	120	52	34.0	9.0
180	187	8	3030	75	S2	158	77	40.5	12.0

Pulley Configuration: S=Solid, P=Plate, A=Arm.
= lightening holes

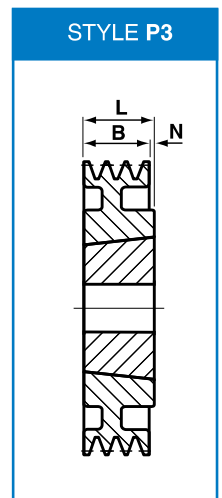
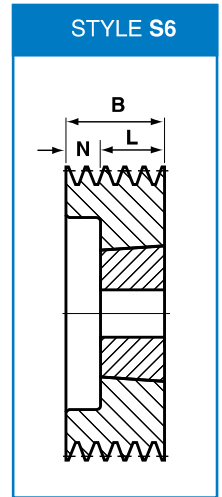
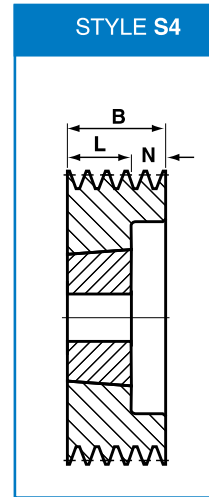
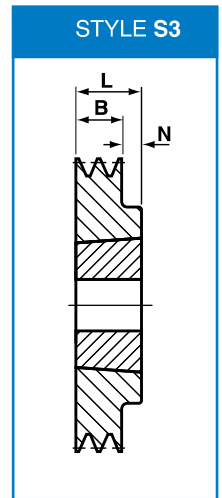
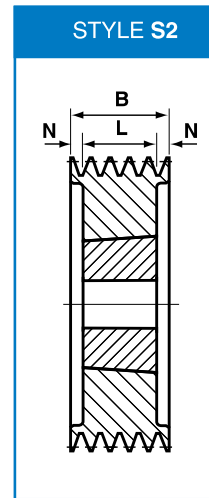

SPB

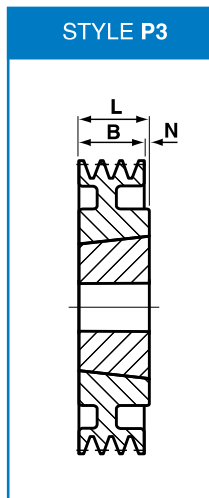
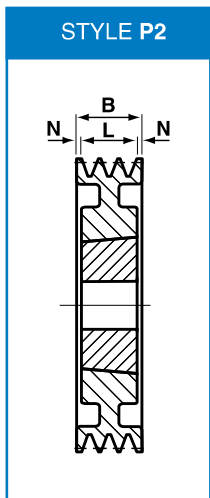
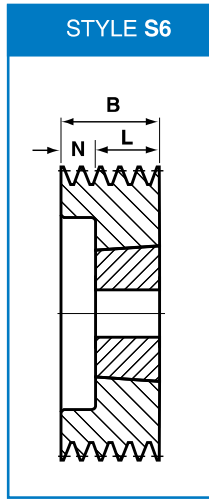
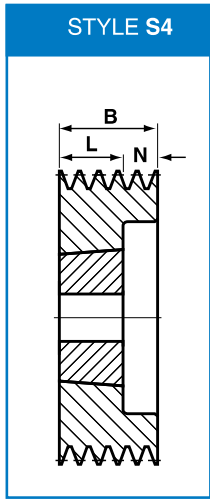
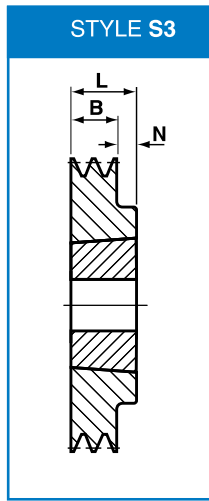
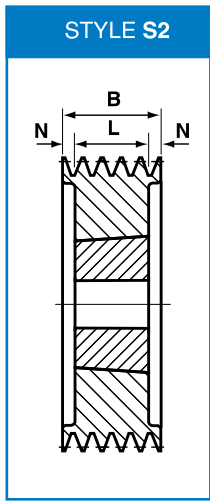

Pitch Dia. dw	Outside Dia. du	Groove No.	Bush Size	Max Bore	Pulley Config. & Style	Rim Width B	L	N	Weight kg
190	197	1	2012	50	P3	25	32	7.0	4.4
190	197	2	2517	65	S3	44	45	1.0	6.5
190	197	3	2517	65	S6	63	45	18.0	7.6
190	197	4	2517	65	S2	82	45	18.5	8.7
190	197	5	3020	75	S2	101	52	24.5	9.1
190	197	6	3020	75	S2	120	52	34.0	10.0
190	197	8	3030	75	S2	158	77	40.5	13.0
200	207	1	2012	50	P3	25	32	7.0	4.4
200	207	2	2517	65	P3	44	45	1.0	7.5
200	207	3	2517	65	P4	63	45	18.0	8.8
200	207	4	3020	75	S4	82	52	30.0	9.4
200	207	5	3020	75	S2	101	52	24.5	10.0
200	207	6	3020	75	S2	120	52	34.0	12.0
200	207	8	3535	90	S2	158	89	34.5	15.0
212	219	1	2012	50	P3	25	32	7.0	4.1
212	219	2	2517	65	P3	44	45	1.0	5.9
212	219	3	2517	65	P4	63	45	18.0	7.4
212	219	4	3020	75	S4	82	52	30.0	11.0
212	219	5	3020	75	S2	101	52	24.5	12.0
212	219	6	3535	90	S2	120	89	15.5	15.0
212	219	8	3535	90	S2	158	89	34.5	18.0
224	231	1	2012	50	P3	25	32	7.0	4.5
224	231	2	2517	65	P3	44	45	1.0	6.4
224	231	3	2517	65	P4	63	45	18.0	8.0
224	231	4	3020	75	S4	82	52	30.0	12.0
224	231	5	3020	75	S2	101	52	24.5	14.0
224	231	6	3535	90	S2	120	89	15.5	18.0
224	231	8	3535	90	S2	158	89	34.5	21.0
224	231	10	3535	90	S2	196	89	53.5	23.0
236	243	1	2012	50	P3#	25	32	7.0	4.9
236	243	2	2517	65	P3	44	45	1.0	6.9
236	243	3	2517	65	P4	63	45	18.0	8.3
236	243	4	3020	75	S4	82	52	30.0	14.0
236	243	5	3535	90	S4	101	89	12.0	19.0
236	243	6	3535	90	S2	120	89	15.5	21.0
236	243	8	3535	90	S2	158	89	34.5	24.0
236	243	10	3535	90	S2	196	89	53.5	26.0
250	257	1	2012	50	P3#	25	32	7.0	5.5
250	257	2	2517	65	P3#	44	45	1.0	7.3
250	257	3	3020	75	P4	63	52	11.0	10.0
250	257	4	3020	75	P4	82	52	30.0	12.0
250	257	5	3535	90	S4	101	89	12.0	23.0
250	257	6	3535	90	S2	120	89	15.5	24.0
250	257	8	3535	90	S2	158	89	34.5	27.0
250	257	10	3535	90	S2	196	89	53.5	31.0
280	287	1	2012	50	A3	25	32	7.0	6.5
280	287	2	2517	65	A3	44	45	1.0	9.1
280	287	3	3020	75	P4#	63	52	11.0	12.0
280	287	4	3020	75	P2#	82	52	15.0	14.0
280	287	5	3535	90	P2	101	89	6.0	20.0
280	287	6	3535	90	P2	120	89	15.5	22.0
280	287	8	3535	90	P2	158	89	34.5	25.0
280	287	10	3535	90	P2	196	89	53.5	29.0
300	307	1	2012	50	A3	25	32	7.0	6.8
300	307	2	2517	65	A3	44	45	1.0	8.6
300	307	3	3020	75	P4#	63	52	11.0	9.8
300	307	4	3535	90	P3	82	89	7.0	14.5
300	307	5	3535	90	P2	101	89	6.0	19.5
300	307	6	3535	90	P2	120	89	15.5	22.0
300	307	8	3535	90	P2	158	89	34.5	41.0
300	307	10	3535	90	P2	196	89	53.5	33.0

Pulley Configuration: S=Solid, P=Plate, A=Arm.
= lightening holes

Pitch Dia. dw	Outside Dia. du	Groove No.	Bush Size	Max Bore	Pulley Config. & Style	Rim Width B	L	N	Weight kg
315	322	1	2012	50	A3	25	32	7.0	7.9
315	322	2	2517	65	A3	44	45	1.0	11.0
315	322	3	3020	75	A4	63	52	11.0	14.0
315	322	4	3535	90	P3#	82	89	7.0	20.0
315	322	5	3535	90	P2	101	89	6.0	23.0
315	322	6	3535	90	P2#	120	89	15.5	25.0
315	322	8	3535	90	P2	158	89	34.5	29.0
315	322	10	3535	90	P2	196	89	53.5	33.0
335	342	2	2517	65	A3	44	45	7.0	11.3
335	342	3	3020	75	A4	63	52	11.0	12.0
335	342	4	3535	90	A3	82	89	7.0	18.4
335	342	5	3535	90	A2	101	89	6.0	19.6
335	342	6	3535	90	A2	120	89	15.5	22.0
335	342	8	3535	90	P2#	158	89	34.5	29.0
335	342	10	4040	100	P2	196	102	47.0	37.0
355	362	2	3020	75	A3	44	52	8.0	14.0
355	362	3	3020	75	A4	63	52	11.0	17.0
355	362	4	3535	90	A3	82	89	7.0	24.0
355	362	5	3535	90	A2	101	89	6.0	26.0
355	362	6	3535	90	A2	120	89	15.5	29.0
355	362	8	3535	90	A2	158	89	34.5	34.0
355	362	10	4040	100	P2#	196	102	47.0	41.0
400	407	2	3020	75	A3	44	52	8.0	11.4
400	407	3	3535	90	A3	63	89	26.0	17.0
400	407	4	3535	90	A3	82	89	7.0	22.0
400	407	5	3535	90	A2	101	89	6.0	25.5
400	407	6	3535	90	A2	120	89	15.5	28.5
400	407	8	4040	100	A2	158	102	28.0	41.0
400	407	10	4040	100	A2	196	102	47.0	46.0
450	457	2	3020	75	A3	44	52	8.0	14.0
450	457	3	3535	90	A3	63	89	26.0	22.0
450	457	4	3535	90	A3	82	89	7.0	25.5
450	457	5	3535	90	A2	101	89	6.0	29.0
450	457	6	4040	100	A2	120	102	9.0	35.0
450	457	8	4040	100	A2	158	102	28.0	52.0
450	457	10	4545	110	A2	196	114	41.0	56.0
500	507	2	3020	75	A3	44	52	8.0	15.5
500	507	3	3535	90	A3	63	89	26.0	24.0
500	507	4	3535	90	A3	82	89	7.0	28.0
500	507	5	3535	90	A2	101	89	6.0	32.0
500	507	6	4040	100	A2	120	102	9.0	49.0
500	507	8	4040	100	A2	158	102	28.0	58.0
500	507	10	4545	110	A2	196	114	41.0	58.0
560	567	2	3020	75	A3	44	52	8.0	25.0
560	567	3	3535	90	A3	63	89	26.0	26.0
560	567	4	3535	90	A3	82	89	7.0	31.0
560	567	5	4040	100	A3	101	102	1.0	39.0
560	567	6	4040	100	A2	120	102	9.0	42.5
560	567	8	4545	110	A2	158	114	22.0	59.0
560	567	10	4545	110	A2	196	114	41.0	66.0
630	637	2	3030	75	A3	44	77	33.0	19.3
630	637	3	3535	90	A3	63	89	26.0	31.0
630	637	4	3535	90	A3	82	89	7.0	36.5
630	637	5	4040	100	A3	101	102	1.0	44.5
630	637	6	4040	100	A2	120	102	9.0	51.0
630	637	8	4545	110	A2	158	114	22.0	66.0
630	637	10	4545	110	A2	196	114	41.0	75.0

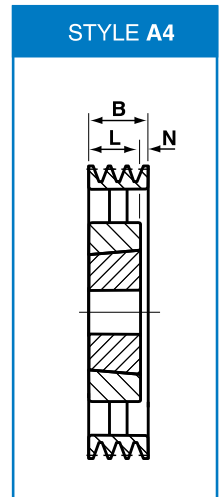
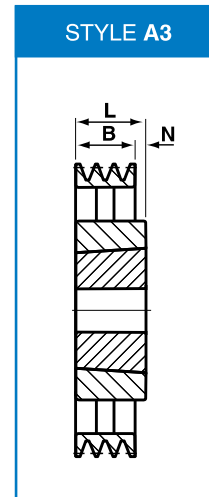
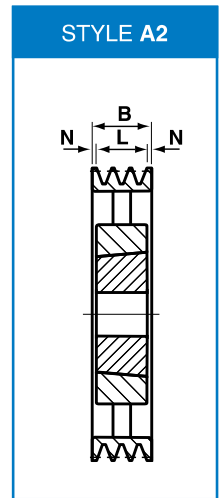
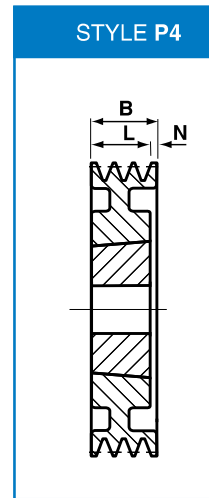

Pulley Configuration: S=Solid, P=Plate, A=Arm.
= lightening holes

SPB

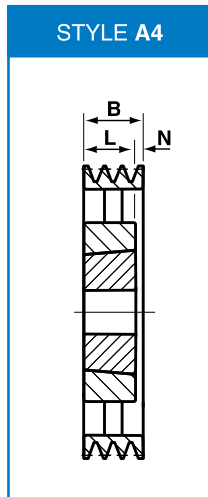
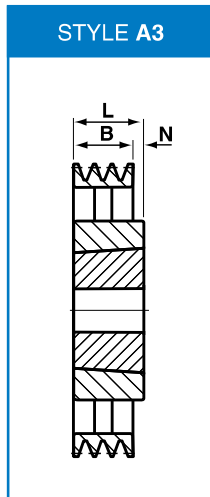
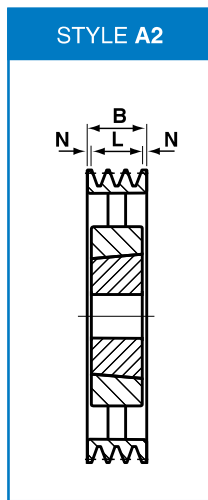
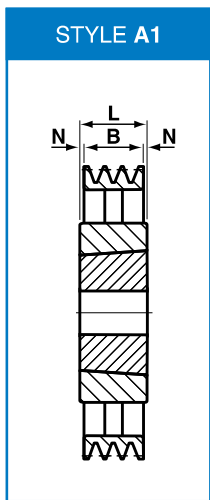

Pitch Dia. dw	Outside Dia. du	Groove No.	Bush Size	Max Bore	Pulley Config. & Style	Rim Width B	L	N	Weight kg
710	717	3	3535	90	A3	63	89	26.0	36
710	717	4	3535	90	A3	82	89	7.0	41
710	717	5	4040	100	A3	101	102	1.0	51
710	717	6	4545	110	A4	120	114	6.0	59
710	717	8	4545	110	A2	158	114	22.0	78
710	717	10	4545	110	A2	196	114	41.0	88
800	807	3	3535	90	A3	63	89	26.0	38
800	807	4	4040	100	A3	82	102	20.0	48
800	807	5	4040	100	A3	101	102	1.0	56
800	807	6	4545	110	A4	120	114	6.0	66
800	807	8	4545	110	A2	158	114	22.0	100
800	807	10	4545	110	A2	196	114	41.0	110
900	907	3	3535	90	A3	63	89	26.0	50
900	907	4	4040	100	A3	82	102	20.0	88
900	907	5	4545	110	A1	101	114	6.5	114
900	907	6	4545	110	A4	120	114	6.0	120
900	907	8	4545	110	A2	158	114	22.0	132
900	907	10	5050	125	A2	196	127	34.5	140
1000	1007	3	4040	100	A3	63	102	39.0	70
1000	1007	4	4040	100	A3	82	102	20.0	78
1000	1007	5	4545	110	A1	101	114	6.5	93
1000	1007	6	4545	110	A4	120	114	6.0	100
1000	1007	8	5050	125	A2	158	127	15.5	140
1000	1007	10	5050	125	A2	196	127	34.5	150
1250	1257	3	4040	100	A1	63	102	19.5	75
1250	1257	4	4545	110	A1	82	114	16.0	158
1250	1257	5	4545	110	A1	101	114	6.5	179
1250	1257	6	5050	125	A3	120	127	7.0	180
1250	1257	8	5050	125	A2	158	127	15.5	224
1250	1257	10	5050	125	A2	196	127	35.0	320

Pulley Configuration: S=Solid, P=Plate, A=Arm.
 # = lightening holes

Pitch Dia. dw	Outside Dia. du	Groove No.	Bush Size	Max Bore	Pulley Config. & Style	Rim Width B	L	N	Weight kg
200	209.5	3	2517	65	S2	85.0	45	20.0	10.2
200	209.5	4	3020	75	S2	110.5	52	29.3	11.0
200	209.5	5	3535	90	S2	136.0	89	23.5	12.5
200	209.5	6	3535	90	S2	161.5	89	36.3	17.5
200	209.5	8	3535	90	S2	212.5	89	61.8	18.5
212	221.5	3	3020	75	S2	85.0	52	16.5	11.0
212	221.5	4	3020	75	S2	110.5	52	29.8	13.5
212	221.5	5	3535	90	S2	136.0	89	23.5	14.5
212	221.5	6	3535	90	S2	161.5	89	36.3	19.0
212	221.5	8	3535	90	S2	212.5	89	61.8	22.1
224	233.5	3	3020	75	S2	85.0	52	16.5	12.0
224	233.5	4	3535	90	S2	110.5	89	10.8	16.0
224	233.5	5	3535	90	S2	136.0	89	23.5	18.0
224	233.5	6	3535	90	S2	161.5	89	36.3	20.0
224	233.5	8	3535	90	S2	212.5	89	61.8	25.0
236	245.5	3	3020	75	S2	85.0	52	16.5	14.0
236	245.5	4	3535	90	S2	110.5	89	10.8	19.0
236	245.5	5	3535	90	S2	136.0	89	23.5	21.0
236	245.5	6	3535	90	S2	161.5	89	36.3	23.0
236	245.5	8	3535	90	S2	212.5	89	61.8	28.0
250	259.5	3	3020	75	P2	85.0	52	16.5	13.0
250	259.5	4	3535	90	S2	110.5	89	10.8	22.0
250	259.5	5	3535	90	S2	136.0	89	23.5	25.0
250	259.5	6	3535	90	S2	161.5	89	36.3	27.0
250	259.5	8	3535	90	S2	212.5	89	61.8	32.0
250	259.5	10	4040	100	S2	263.5	102	80.8	35.0
265	274.5	3	3535	90	S3	85.0	89	4.0	24.0
265	274.5	4	3535	90	S2	110.5	89	10.8	26.0
265	274.5	5	3535	90	S2	136.0	89	23.5	29.0
265	274.5	6	3535	90	S2	161.5	89	36.3	31.0
265	274.5	8	3535	90	S2	212.5	89	61.8	36.0
265	274.5	10	4040	100	S2	263.5	102	80.8	60.0
280	289.5	3	3535	90	P3	85.0	89	4.0	19.0
280	289.5	4	3535	90	P2	110.5	89	10.8	21.0
280	289.5	5	3535	90	P2	136.0	89	23.5	24.0
280	289.5	6	3535	90	P2	161.5	89	36.3	36.0
280	289.5	8	3535	90	S2	212.5	89	61.8	41.0
280	289.5	10	4040	100	S2	263.5	102	80.8	46.0
300	309.5	3	3535	90	P3	85.0	89	4.0	21.0
300	309.5	4	3535	90	P2	110.5	89	10.8	24.0
300	309.5	5	3535	90	P2	136.0	89	23.5	24.0
300	309.5	6	3535	90	P2	161.5	89	36.3	29.0
300	309.5	8	4040	100	S2	212.5	102	55.3	48.0
300	309.5	10	4545	110	S2	263.5	114	74.8	54.0
315	324.5	3	3535	90	P3#	85.0	89	4.0	21.0
315	324.5	4	3535	90	P2#	110.5	89	10.8	24.0
315	324.5	5	3535	90	P2#	136.0	89	23.5	28.0
315	324.5	6	3535	90	P2	161.5	89	36.3	31.0
315	324.5	8	4040	100	P2	212.5	102	55.3	54.0
315	324.5	10	4545	110	S2	263.5	114	74.8	60.0
335	344.5	3	3535	90	P3#	85.0	89	4.0	24.0
335	344.5	4	3535	90	P2#	110.5	89	10.8	27.0
335	344.5	5	3535	90	P2#	136.0	89	23.5	31.0
335	344.5	6	3535	90	P2#	161.5	89	36.3	34.0
335	344.5	8	4040	100	P2	212.5	102	55.3	45.0
335	344.5	10	4545	110	S2	263.5	114	74.8	85.0
335	344.5	12	5050	125	S2	314.5	127	50-137	111.0
355	364.5	3	3535	90	A3	85.0	89	4.0	26.0
355	364.5	4	3535	90	A2	110.5	89	10.8	30.0
355	364.5	5	3535	90	A2	136.0	89	23.5	34.0
355	364.5	6	3535	90	A2	161.5	89	36.3	37.0
355	364.5	8	4040	100	P2	212.5	102	55.3	48.0
355	364.5	10	4545	110	S2	263.5	114	74.8	81.0
355	364.5	12	5050	125	S2	314.5	127	50-137	124.0

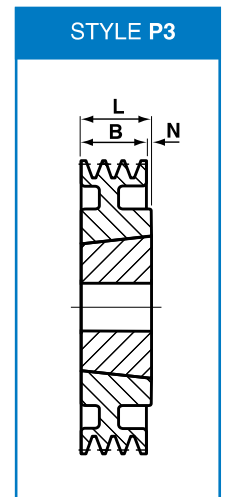
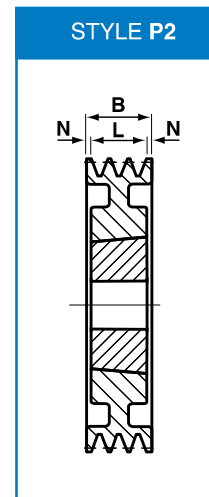
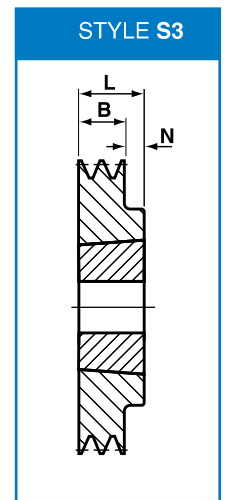
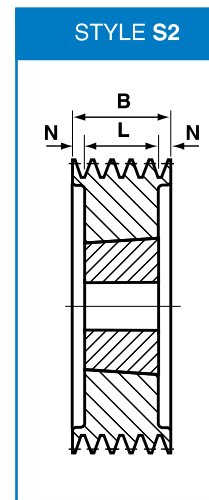

Note
Dimension 'N' on SPC 12 groove pulleys is shown as 50mm - 137mm. The 137mm is the dimension from the edge of the pulley to the taper bush entry end of the hub

Pulley Configuration: S=Solid, P=Plate, A=Arm.
= lightening holes

SPC

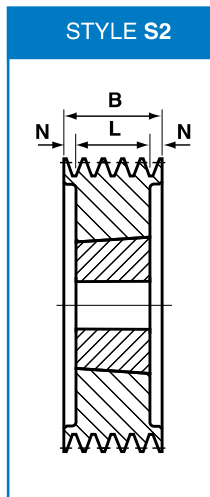
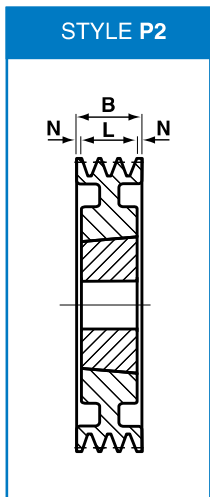
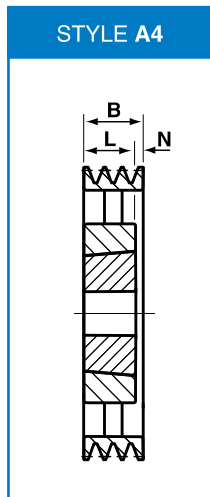
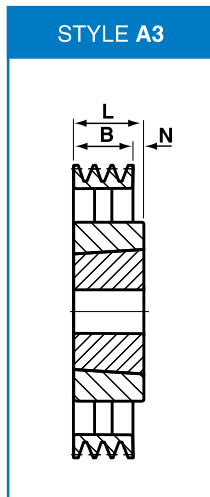
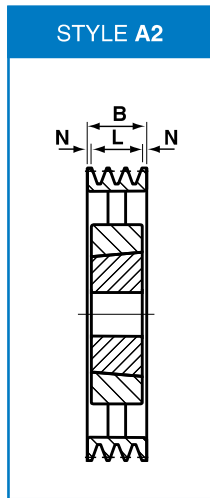
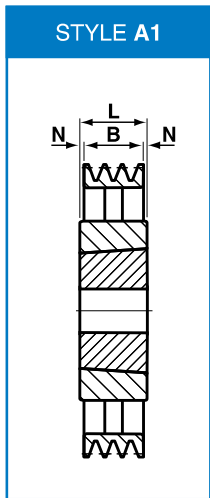

Note
Dimension 'N' on SPC 12 groove pulleys is shown as 50mm - 137mm. The 137mm is the dimension from the edge of the pulley to the taper bush entry end of the hub

Pulley Configuration: S=Solid, P=Plate, A=Arm.
= lightening holes

Pitch Dia. dw	Outside Dia. du	Groove No.	Bush Size	Max Bore	Pulley Config. & Style	Rim Width B	L	N	Weight kg
375	384.5	3	3535	90	A3	85.0	89	4.0	29.0
375	384.5	4	3535	90	A2	110.5	89	10.8	33.0
375	384.5	5	3535	90	A2	136.0	89	23.5	36.0
375	384.5	6	4040	100	A2	161.5	102	29.8	44.0
375	384.5	8	4545	110	P2	212.5	114	49.3	57.0
375	384.5	10	4545	110	S2	263.5	114	74.8	92.0
375	384.5	12	5050	125	S2	314.5	127	50-137	138.0
400	409.5	3	3535	90	A3	85.0	89	4.0	31.0
400	409.5	4	3535	90	A2	110.5	89	10.8	35.0
400	409.5	5	3535	90	A2	136.0	89	23.5	40.0
400	409.5	6	4040	100	A2	161.5	102	29.8	48.0
400	409.5	8	4545	110	P2	212.5	114	49.3	62.0
400	409.5	10	5050	125	P2	263.5	127	68.3	73.0
400	409.5	12	5050	125	S2	314.5	127	50-137	156.0
425	434.5	3	3535	90	A3	85.0	89	4.0	37.0
425	434.5	4	3535	90	A2	110.5	89	10.8	42.0
425	434.5	5	3535	90	A2	136.0	89	23.5	46.0
425	434.5	6	4040	100	A2	161.5	102	29.8	56.0
425	434.5	8	4545	110	A2	212.5	114	49.3	68.0
425	434.5	10	5050	125	P2	263.5	127	68.3	105.0
425	434.5	12	5050	125	P2	314.5	127	50-137	130.0
450	459.5	3	3535	90	A3	85.0	89	4.0	34.0
450	459.5	4	3535	90	A2	110.5	89	10.8	39.0
450	459.5	5	4040	100	A2	136.0	102	17.0	49.0
450	459.5	6	4545	110	A2	161.5	114	23.8	67.0
450	459.5	8	5050	125	A2	212.5	127	42.8	81.0
450	459.5	10	5050	125	P2#	263.5	127	68.3	94.0
450	459.5	12	5050	125	A2	314.5	127	50-137	133.0
475	484.5	3	3535	90	A3	85.0	89	4.0	30.0
475	484.5	4	3535	90	A2	110.5	89	10.8	37.0
475	484.5	5	4040	100	A2	136.0	102	17.0	48.0
475	484.5	6	4545	110	A2	161.5	114	23.8	65.0
475	484.5	8	5050	125	A2	212.5	127	42.8	100.0
475	484.5	10	5050	125	A2	263.5	127	68.3	125.0
475	484.5	12	5050	125	A2	314.5	127	50-137	142.0
500	509.5	3	3535	90	A3	85.0	89	4.0	31.9
500	509.5	4	3535	90	A2	110.5	89	10.8	44.0
500	509.5	5	4040	100	A2	136.0	102	17.0	54.0
500	509.5	6	4545	110	A2	161.5	114	23.8	67.0
500	509.5	8	5050	125	A2	212.5	127	42.8	91.0
500	509.5	10	5050	125	A2	263.5	127	68.3	111.0
500	509.5	12	5050	125	A2	314.5	127	50-137	148.0
530	539.5	3	3535	90	A3	85.0	89	4.0	34.5
530	539.5	4	4040	100	A4	110.5	102	8.5	45.0
530	539.5	5	4545	110	A2	136.0	114	11.0	56.0
530	539.5	6	5050	125	A2	161.5	127	17.3	73.0
530	539.5	8	5050	125	A2	212.5	127	42.8	105.0
530	539.5	10	5050	125	A2	263.5	127	68.3	145.0
530	539.5	12	5050	125	A2	314.5	127	50-137	155.0
560	569.5	3	3535	90	A3	85.0	89	4.0	37.0
560	569.5	4	4040	100	A4	110.5	102	8.5	60.0
560	569.5	5	4545	110	A2	136.0	114	11.0	60.0
560	569.5	6	5050	125	A2	161.5	127	17.3	85.0
560	569.5	8	5050	125	A2	212.5	127	42.8	101.0
560	569.5	10	5050	125	A2	263.5	127	68.3	121.0
560	569.5	12	5050	125	A2	314.5	127	50-137	164.0
630	639.5	3	4040	100	A1	85.0	102	8.5	49.5
630	639.5	4	4545	110	A3	110.5	114	3.5	114.0
630	639.5	5	5050	125	A4	136.0	127	9.0	91.0
630	639.5	6	5050	125	A2	161.5	127	17.3	97.0
630	639.5	8	5050	125	A2	212.5	127	42.8	116.0
630	639.5	10	5050	125	A2	263.5	127	68.3	130.0
630	639.5	12	5050	125	A2	314.5	127	50-137	185.0

Pitch Dia. dw	Outside Dia. du	Groove No.	Bush Size	Max Bore	Pulley Config. & Style	Rim Width B	L	N	Weight kg
710	719.5	3	4040	100	A1	85.0	102	8.5	57.0
710	719.5	4	4545	110	A3	110.5	114	3.5	70.3
710	719.5	5	5050	125	A4	136.0	127	9.0	92.0
710	719.5	6	5050	125	A2	161.5	127	17.3	100.0
710	719.5	8	5050	125	A2	212.5	127	42.8	130.0
710	719.5	10	5050	125	A2	263.5	127	68.3	145.0
710	719.5	12	6050	150	A2	314.5	127	50-137	230.0
800	809.5	3	4545	110	A1	85.0	114	14.5	65.0
800	809.5	4	5050	125	A1	110.5	127	8.3	76.5
800	809.5	5	5050	125	A4	136.0	127	9.0	143.0
800	809.5	6	5050	125	A2	161.5	127	17.3	120.0
800	809.5	8	5050	125	A2	212.5	127	42.8	150.0
800	809.5	10	5050	125	A2	263.5	127	68.3	170.0
800	809.5	12	6050	150	A2	314.5	127	50-137	277.0
1000	1009.5	3	5050	125	A1	85.0	127	21.0	116.0
1000	1009.5	4	5050	125	A1	110.5	127	8.3	125.0
1000	1009.5	5	5050	125	A4	136.0	127	9.0	143.0
1000	1009.5	6	5050	125	A2	161.5	127	17.3	155.0
1000	1009.5	8	5050	125	A2	212.5	127	42.8	205.0
1000	1009.5	10	5050	125	A2	263.5	127	68.3	230.0
1000	1009.5	12	6050	150	A2	314.5	127	50-137	346.0
1250	1259.5	4	5050	125	A1	110.5	127	8.3	214.0
1250	1259.5	5	5050	125	A4	136.0	127	9.0	187.0
1250	1259.5	6	5050	125	A2	161.5	127	17.3	200.0
1250	1259.5	8	5050	125	A2	212.5	127	42.8	252.0
1250	1259.5	10	5050	125	A2	263.5	127	68.3	300.0
1250	1259.5	12	6050	150	A2	314.5	127	50-137	435.0

Pulley Configuration: S=Solid, P=Plate, A=Arm.
 # = lightening holes

Note
 Dimension 'N' on SPC 12 groove pulleys is shown as 50mm - 137mm. The 137mm is the dimension from the edge of the pulley to the taper bush entry end of the hub

Note 2
 Larger taper bored pulleys utilising taper bush sizes 6050, 7060 and 8065 are also available to order.
 Challenge manufacture pulleys up to a maximum of 2400mm diameter with 20 grooves in pilot or taper bore

