

Plain Bore Pulleys for 'L' Series Timing Belts

Catalogue No.	No. Teeth Z	Pulley Type	Pitch Circle Diameter dp	Min. Bore d	Max Bore d	Outside Diameter do	Flange Diameter A	Pulley Width F	Bore Length L	Hub Diameter M	Rim Diameter N	Approx. Weight kg
3/8" Pitch Pulleys for 1/2" wide Belts. Ref. L050												
P10L050	10	1F	30.32	8	13	29.6	37	19	28	20	-	0.12
P12L050	12	1F	36.38	8	15	35.6	43	19	30	24	-	0.16
P13L050	13	1F	39.41	8	19	38.7	44	19	30	28	-	0.19
P14L050	14	1F	42.45	8	19	41.7	48	19	30	28	-	0.22
P15L050	15	1F	45.48	8	23	44.7	51	19	30	34	-	0.29
P16L050	16	1F	48.51	8	24	47.8	54	19	32	36	-	0.34
P17L050	17	1F	51.54	10	24	50.8	57	19	32	36	-	0.38
P18L050	18	1F	54.57	10	27	53.8	60	19	32	40	-	0.42
P19L050	19	1F	57.61	10	27	56.8	64	19	32	40	-	0.46
P20L050	20	1F	60.64	10	27	59.9	67	19	32	40	-	0.50
P21L050	21	1F	63.67	10	30	62.9	70	19	32	45	-	0.57
P22L050	22	1F	66.70	10	30	65.9	75	19	32	45	-	0.61
P23L050	23	1F	69.73	10	36	69.0	79	19	32	55	-	0.71
P24L050	24	1F	72.77	10	36	72.0	79	19	32	58	-	0.81
P25L050	25	1F	75.80	10	38	75.0	83	19	32	58	-	0.85
P26L050	26	1F	78.83	11	38	78.1	87	19	32	58	-	0.91
P27L050	27	1F	81.86	11	38	81.1	87	19	32	58	-	0.97
P28L050	28	1F	84.89	11	38	84.1	91	19	32	70	-	1.03
P30L050	30	1F	90.96	11	46	90.2	97	19	32	70	-	1.07
P32L050	32	1F	97.02	11	46	96.3	102	19	32	70	-	1.23
P36L050	36	1F	109.15	11	46	108.4	115	19	32	70	-	1.50
P40L050	40	2F	121.28	11	46	120.5	128	19	32	70	100	1.77
P44L050	44	2F	133.40	11	46	132.6	142	19	32	70	112	2.20
P48L050	48	2F	145.53	11	46	144.8	150	19	32	70	124	2.68
P60L050	60	2	181.91	14	45	181.2	-	19	42	75	160	3.10
P72L050	72	2	218.30	14	45	217.5	-	19	42	75	197	4.86
P84L050	84	2	254.68	14	45	253.9	-	19	42	75	233	5.00
P96L050	96	2	291.06	14	45	290.3	-	19	42	75	269	6.00
3/8" Pitch Pulleys for 3/4" wide Belts. Ref. L075												
P10L075	10	1F	30.32	8	13	29.6	37	25	38	20	-	0.18
P12L075	12	1F	36.38	8	15	35.6	43	25	38	24	-	0.22
P13L075	13	1F	39.41	8	19	38.7	44	25	38	28	-	0.25
P14L075	14	1F	42.45	11	19	41.7	48	25	38	28	-	0.27
P15L075	15	1F	45.48	11	23	44.7	51	25	38	34	-	0.34
P16L075	16	1F	48.51	11	24	47.8	54	25	38	36	-	0.43
P17L075	17	1F	51.54	11	27	50.8	57	25	38	36	-	0.47
P18L075	18	1F	54.57	11	27	53.8	60	25	38	40	-	0.51
P19L075	19	1F	57.61	11	27	56.8	64	25	38	40	-	0.55
P20L075	20	1F	60.64	11	30	59.9	67	25	38	40	-	0.59
P21L075	21	1F	63.67	11	30	62.9	70	25	38	45	-	0.64
P22L075	22	1F	66.70	11	30	65.9	75	25	38	45	-	0.77
P23L075	23	1F	69.73	11	36	69.0	79	25	38	55	-	0.85
P24L075	24	1F	72.77	11	36	72.0	79	25	38	55	-	0.97
P25L075	25	1F	75.80	11	38	75.0	83	25	38	58	-	1.02
P26L075	26	1F	78.83	11	38	78.1	87	25	38	58	-	1.08
P27L075	27	1F	81.86	11	38	81.1	87	25	38	58	-	1.18
P28L075	28	1F	84.89	11	38	84.1	91	25	38	58	-	1.20
P30L075	30	1F	90.96	11	46	90.2	97	25	38	70	-	1.37
P32L075	32	1F	97.02	11	46	96.3	102	25	38	70	-	1.54
P36L075	36	1F	109.15	11	46	108.4	115	25	38	70	-	1.89
P40L075	40	2F	121.28	11	46	120.5	128	25	38	70	100	2.35
P44L075	44	2F	133.40	11	46	132.6	142	25	38	70	112	2.75
P48L075	48	2F	145.53	11	46	144.8	150	25	38	70	124	3.19
P60L075	60	2	181.91	14	45	181.2	-	25	45	75	160	3.44
P72L075	72	2	218.30	14	45	217.5	-	25	45	75	197	4.58
P84L075	84	2	254.68	14	45	253.9	-	25	45	75	233	5.60
P96L075	96	2	291.06	14	45	290.3	-	25	45	75	269	7.00
3/8" Pitch Pulleys for 1" wide Belts. Ref. L100												
P10L100	10	1F	30.32	8	13	29.6	37	32	45	20	-	0.18
P12L100	12	1F	36.38	8	15	35.6	43	32	45	24	-	0.26
P13L100	13	1F	39.41	8	19	38.7	44	32	45	28	-	0.30
P14L100	14	1F	42.45	11	19	41.7	48	32	45	28	-	0.34
P15L100	15	1F	45.48	11	23	44.7	51	32	45	34	-	0.41
P16L100	16	1F	48.51	11	24	47.8	54	32	45	36	-	0.48
P17L100	17	1F	51.54	11	24	50.8	57	32	45	36	-	0.55
P18L100	18	1F	54.57	11	27	53.8	60	32	45	40	-	0.62
P19L100	19	1F	57.61	11	27	56.8	64	32	45	40	-	0.70
P20L100	20	1F	60.64	11	27	59.9	67	32	45	40	-	0.72
P21L100	21	1F	63.67	11	30	62.9	70	32	45	45	-	0.77
P22L100	22	1F	66.70	11	30	65.9	75	32	45	45	-	0.88
P23L100	23	1F	69.73	11	36	69.0	79	32	45	45	-	1.12
P24L100	24	1F	72.77	11	36	72.0	79	32	45	55	-	1.16
P25L100	25	1F	75.80	11	38	75.0	83	32	45	58	-	1.18
P26L100	26	1F	78.83	11	38	78.1	87	32	45	58	-	1.24
P27L100	27	1F	81.86	11	38	81.1	87	32	45	58	-	1.35
P28L100	28	1F	84.89	11	38	84.1	91	32	45	58	-	1.42
P30L100	30	1F	90.96	11	46	90.2	97	32	45	70	-	1.61
P32L100	32	1F	97.02	11	46	96.3	102	32	45	70	-	1.84
P36L100	36	1F	109.15	11	46	108.4	115	32	45	70	-	2.32
P40L100	40	2F	121.28	11	46	120.5	128	32	45	70	100	2.86
P44L100	44	2F	133.40	11	46	132.6	142	32	45	70	112	3.36
P48L100	48	2F	145.53	11	46	144.8	150	32	45	70	124	3.86
P60L100	60	2	181.91	14	45	181.2	-	32	50	75	160	3.55
P72L100	72	2	218.30	14	45	217.5	-	32	50	75	197	5.00
P84L100	84	2	254.68	14	45	253.9	-	32	50	75	233	6.30
P96L100	96	2	291.06	14	45	290.3	-	32	50	75	269	8.20

Pulley Types

The Pulley types referred to in tables are as drawings below. Suffix 'F' indicates pulley has flanges. Pulley below dividing line in tables are manufactured in cast iron.

Std. Pulleys can be reworked to customers bore and keyway requirements.

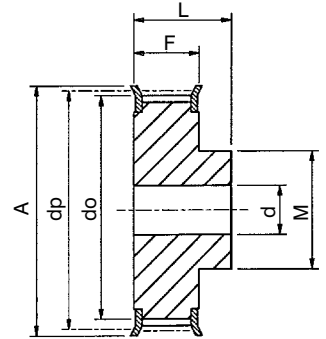

Type 1F

Material: Steel

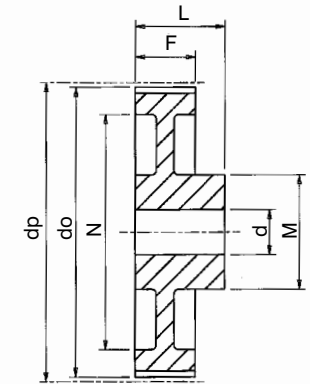

Type 2

Material: Cast Iron
Webs have lightening holes

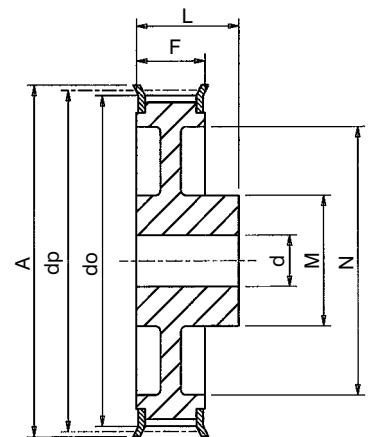

Type 2F

Material: Cast Iron
Webs have lightening holes

All dimensions in mm. Other sizes of Pulleys can be supplied on short delivery. All Pulleys can be supplied finish bored and keywayed. Parallel bore pulleys can be machined and fitted with bearings for idler pulleys. When using pulleys as inside idlers it is recommended that number of teeth of idler should be more than that of smaller drive pulley.